



725 lb. High Capacity Model

274101

Power LiftKar HD

Two Models

Uni – straight frame – accepts dolly option for 4-wheel support.

Fold – upper handle angle can be adjusted. Best for copiers, safes, heavy motors or any short and heavy load which would require the user to pull the load back to a very low position. The adjustable angle position on the Fold model allows the user to stand upright when using the truck at a very low angle.

- Innovative edge-of-step braking system – automatically applies brake when wheels are at edge of step. Helps prevent loss of load control caused by accidental rolling down steps.
- Brake can be shut off for use on level ground – prevents unwanted braking when moving over ground with an uneven surface.
- Two operating modes: single step (ascend or descend button must be pressed after each step – ideal for maximum control), or continuous climb.
- 24v quick-change battery pack – sealed maintenance-free battery.
- Two climbing speeds: 6 steps/min. or 10 steps/min.
- Average number of steps with fully charged battery:
440 lbs. of cargo - 220 steps
550 lbs. of cargo - 190 steps
725 lbs. of cargo - 120 steps.

Power LiftKar Options

- **Part # 274103 - Snap-on toe plate** equipped with 4 dual casters. Provides additional cargo space and the ability to move loads without tilting truck. Especially useful in confined areas.
- **Part # 274102 - Fold-out rear wheel carriage** (Universal model only) slides easily into position to provide 4-wheel support.
- **Part # 274116 - Extra battery pack.**

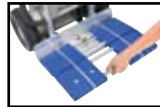

Part #274100 with optional snap-on toe plate - #274103.



Part #274100 with optional fold-out wheel carriage - #274102

OVERALL DIMENSIONS

w:	21"	21"
h:	63"	47" - folded
d:	19"	19"



DC-66 with WLF Option



StairKing Battery Powered Stair Climbing Appliance Truck

- **U.S. Pat. No. 7,137,464**
- 1/2 Horsepower, 50 amp, high torque motor runs cooler under load.
- Industrial grade gear box transmits steady power and is preferable to other drive designs.
- Large 2" diameter, polyurethane lifting feet provide more secure stair gripping.
- Auto rewind ratchet works first to take the slack out of the cargo belt, and then provides a ratchet crank to securely tighten the load.
- Noseplate measures 24" by 4" deep. Welded magnesium frame and noseplate.
- Sealed maintenance-free battery. Charger and circuit breaker included.
- 6" moldon rubber wheels.

OVERALL DIMENSIONS

w:	24"
h:	66" or 72"
d:	15"

See page 37 for StairKing Options.

Part #	274100	274101	230051	230052
Mode	Universal	Fold	DC-66	DC-72
Capacity	725 lbs	725 lbs	850 lbs	850 lbs
Ratchet	N/A	N/A	Auto rewind	Auto rewind
Belt	2 piece with clasp - 10'	2 piece with clasp - 10'	2 piece w/clasp	2 piece w/clasp
Height	63" straight frame	47" folded	66" tall frame	72" tall frame
Weight	97 lbs	86 lbs	101 lbs	102 lbs



DC-66
with
WLF Option



WLF
Winch Lift
Option

- Optional aluminum winch lift attachment has 800 lb capacity.
- 3-1/2" Jarvis Advantage® swivel casters for 4 wheel support and mobility.
- Winch equipped with autobraking system.
- 18" forks, adjustable width up to 19" outside dimension.
- 57.25" lift height.
- Factory or field installation.

OVERALL DIMENSIONS

w: 25"
h: 70"
d: 30"



NE-28
Steel Nose
Extension
Option

- Toe plate extension. Easily clips on to standard toe plate and provides 12" deep x 28" wide cargo surface.

OVERALL DIMENSIONS

w: 28"
h: 4"
d: 12"



SP-20
Platform
Option
slips onto
WLF forks

- Platform attachment. Slides in place over winch lift forks to provide a 20" x 20" lifting platform.

OVERALL DIMENSIONS

w: 20"
h: 7"
d: 20"



MSWK
Superwheel
Option

- Superwheel attachment installs in seconds.
- Equipped with 10" x 4" full pneumatic tires. Provides 4 wheel support and eases transport over rough surfaces.

OVERALL DIMENSIONS

w: 11.5"
h: 4.5"
d: 20.5"



KOW
Kick-out Wheel

- Kick-Out 3.5" casters for four wheel stability.



Battery
Charger
Cord

- Charge battery while driving between stops.
- Plugs into cigarette lighter.
- Cable length 20'.
- Charger is included with truck purchase.

StairKing Battery Powered Stair Climbing Appliance Truck

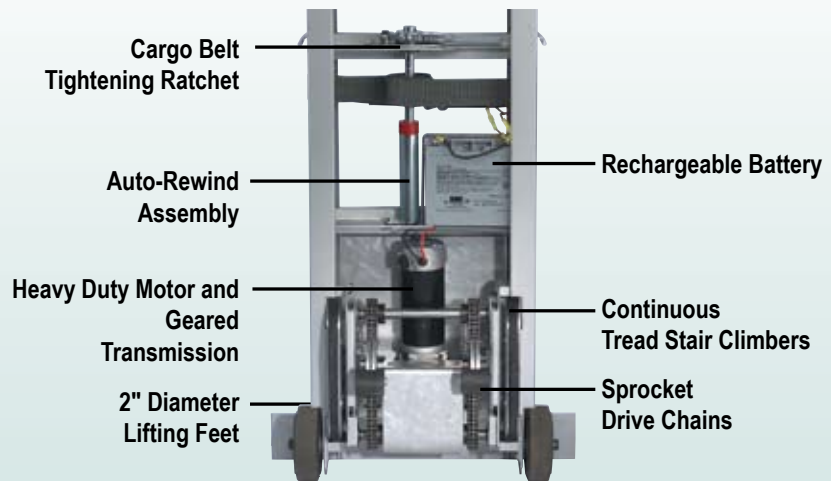

Part #	230053	230055	260160	270076	230059	230060
Model #	WLF	NE-28	SP-20	MSWK	KOW	BC
Capacity	800 lbs	850 lbs	800 lbs	N/A	850 lbs	N/A
Description	Aluminum winch lift attachment*	Steel Nose Extension	Steel Slip on Platform	Superwheel Option	Kick-out Wheel	Cigarette Lighter Charger
Weight	67 lbs	18 lbs	20 lbs	19 lbs	9 lbs	2 lbs